

• **S₀-Interface Transformers**

Electrical specifications @ 25°C:

UMEC Part no.	n ±1%	ΔI _{dc} mA	L _H mH Min.	L _S uH Max.	C _K pF Max.	C _W pF Max.	R _{CU,IC} ΩNOM.	R _{CU,L} ΩNOM.	U _P KVrms	figure/ schematic
Flat design:										
UT 28113	4:1:1	3	22	4	100	20	5,3	1.3	1.5	A
UT28166	2:2:1:1	5	30	5	145	110	5.0	1.6	1.5	B
UT21167	1:1:1:1	5	30	5	120	20	1.6	1.6	1.5	B
UT21168	1.8:1.8:1:1	5	30	5	120	80	4.0	1.6	1.5	B
UT21169	2.5:2.5:1:1	5	30	7	140	200	6.0	1.6	1.5	B
Upright design:										
UT28521	4:1:1	3	22	4	100	20	5,3	1.3	1.5	A
UT21595	2;2:1:1	5	30	5	145	110	5.0	1.6	1.5	B
UT21596	1;1;1;1	5	30	5	120	20	1.6	1.6	1.5	B
UT21597	1.8:1.8:1:1	5	30	5	120	80	4.0	1.6	1.5	B
UT21598	2.5:2.5:1:1	5	30	7	140	200	6.0	1.6	1.5	B
SMT design:										
UT28113-TS	4:1:1	3,6	22	6	105	150	4,9	1,35	2.0	A
UT28113-1TS	4:1:1	1.5	22	6	105	150	4,6	1.35	2.0	A
UT28166-TS	2;2:1:1	5	30	5	145	110	5.0	1.6	1.5	B
UT28167-TS	1;1;1;1	3,6	22	5	120	20	1.6	1.6	1.5	B
UT21168-TS	1.8:1.8:1:1	5	30	5	120	80	4.0	1.6	1.5	B
UT21169-TS	2.5:2.5:1:1	5	30	7	140	200	6.0	1.6	1.5	B
UT28428-TS	2:2:1:1	4	30	3	100		4,8	2,7	1.5	A
Dual Versions:										
UT20495D-TS	1:1:2:2/1:1:2:2	4	30	3	100		5.4	3	1.5	
EN60950-Design:										
UT21711	4;1:1	1	30	3	45	30	2.2	0.4	4.0	A
UT21728	2:1:1	1	25	3	30	60	1.8	0.4	4.0	C
UT28729	2/2:1/1	5	30	15	45	130	3.0	1.3	4.0	B
UT21731	2.5/2.5:1/1	5	30	15	45	200	4.0	1.3	4.0	B
UT21732	1.8/1.8:1/1	5	30	15	45	120	2.6	1.3	4.0	B

*)Ferrite solutions: **UT28xxx**



ISDN S₀-INTERFACE TRANSFORMER:

- Dimensions and connections (tolerance = ±0.2mm)
- UT 21xxx = UT 28xxx-Dimensions

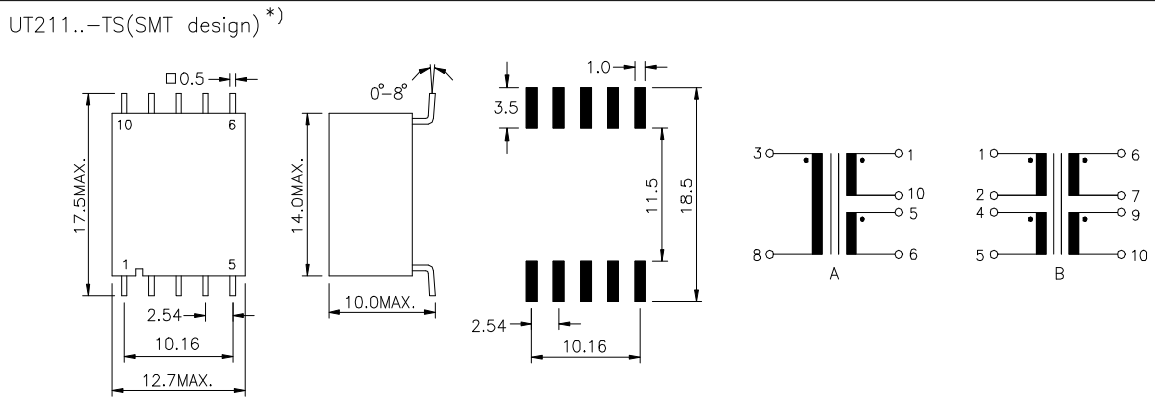
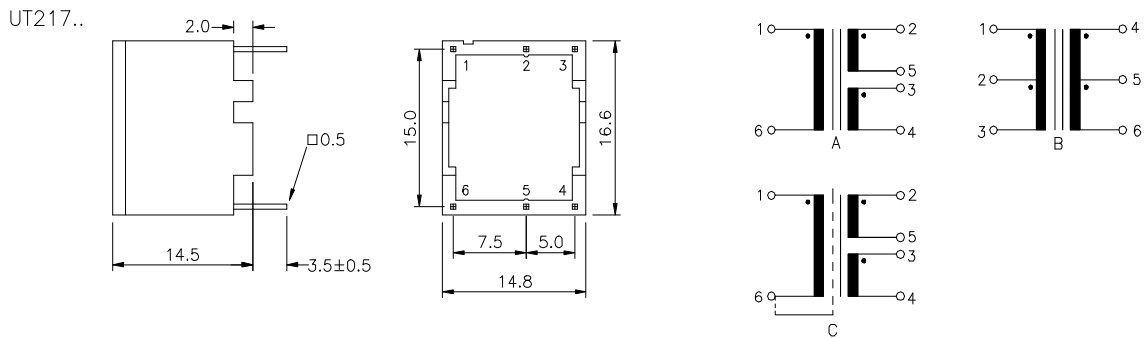
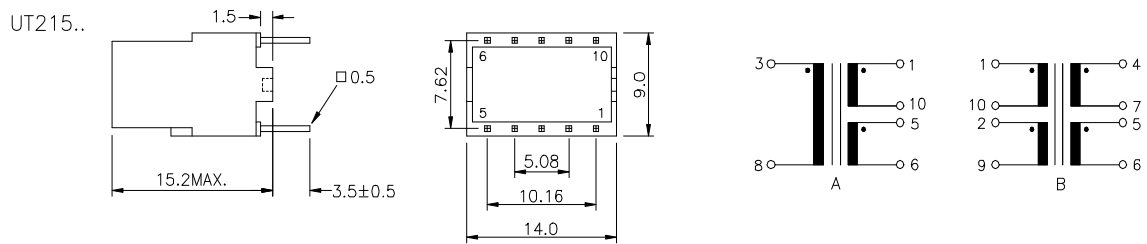
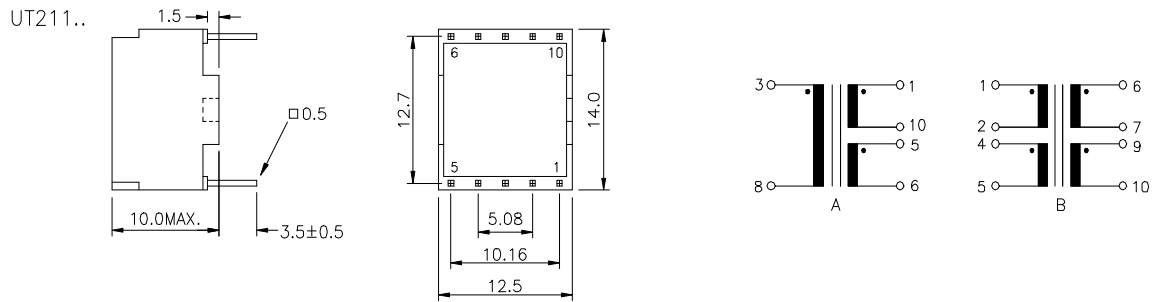

*) pins arrangement according to customer requirement.





ISDN S₀-INTERFACE TRANSFORMER:

UT 284xx-TS (SMT-Design) :

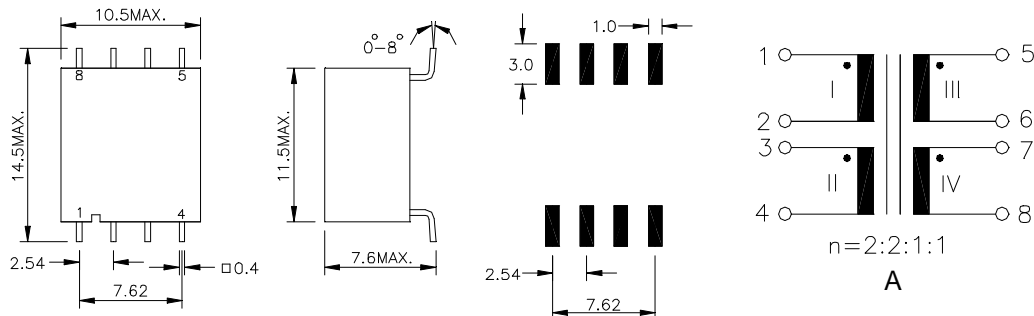

UT20495D-TS (Dual-Version):

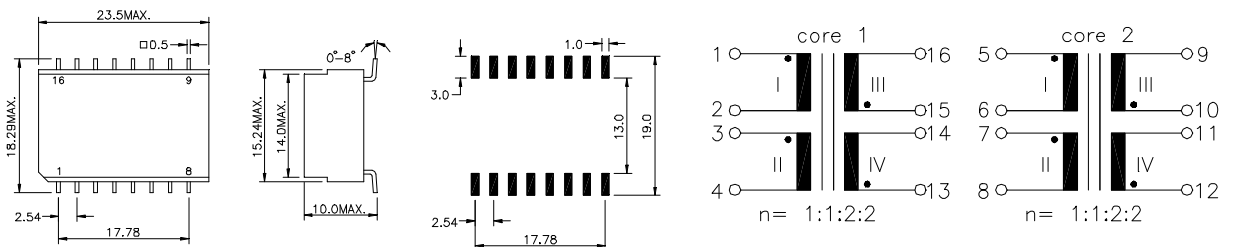

• Definition of symbols:

Transformer:

n = transformer ratio: IC-side:Line-side.

ΔI_{dc} = max. permissible DC unbalance.

L_H = main inductance of winding(s) on Line-side(in series, $f=10\text{KHz}$ $U=100\text{mVrms}$).

L_S = leakage inductance of winding(s) on Line-side with winding(s) on IC-side short circuited(each in series, $f=100\text{KHz}$ $U=100\text{mVrms}$).

C_K = coupling capacitance between the winding(s) on IC-side and the winding(s) on Line-side(So-modules with each choke winding in series, $f=10\text{KHz}$ $U=100\text{mVrms}$).

C_W = winding capacitance of winding(s) on Line-side(in series, nominal value, $f=1\text{MHz}$ $U=1\text{Vrms}$).

$R_{CU,IC}$ = DC resistance of the winding(s) on IC-side(in series, nominal value).

$R_{CU,L}$ = DC resistance of the winding(s) on Line-side(in series, nominal value).

U_P = test voltage, rms value 50/60Hz, 2seconds, winding(s) on Line-side to winding(s) on IC-side.

• General Informations:

Working temp.range: 0°C to 75°C

Packaging: UT 2x1xx: 216 pcs/tray; UT2x5xx: 312 pcs/tray; UT2x7xx: 168 pcs/tray

UT2x1xx-TS: 300pcs/reel; UT2x4xx-TS: 500pcs/reel; UT20495D-TS:200 pcs/reel

Page3/3 02-21SOTrafoUMEU Novt.98



UMEC Europe
Universal Microelectronics

UMEC elektronische Komponenten GmbH
Kreuzenstraße 80 • D-74076 Heilbronn
Tel. 07131/76170 • Fax 07131/761720

Internet: <http://www.umec-europe.com>

e-mail: info@umec.de

<http://www.umec-web.com>